

Module – 1

Semiconductor Diodes and Applications

1. Explain the operation of PN junction diode under forward and reverse bias conditions with the help of V-I characteristics curve.
(Sep '20 – 8M, Jan '20 – 6M, Jan '19 – 7M, MQP '18 – 8M, Jul '18 – 8M, Jan '18 – 6M, Jan '17 – 6M, Jul '16 – 6M)
2. What is PN junction diode? With the help of circuit diagram, explain the V-I characteristics of a diode.
(Jul '19 – 7M, Jul '17 – 6M)
3. Draw and explain the V-I characteristics of a Si (Silicon) diode.
(Jan '19 – 5M, Jan '16 – 8M, Jan '15 – 5M)
4. Draw and explain the V-I characteristics of a Ge (Germanium) diode.
(Jul '15 – 5M)
5. Draw the V-I characteristics of Si and Ge diode.
(Jan '20 – 4M)
6. Draw forward and reverse V-I characteristics of Si and Ge diodes and make any two comparison between Si and Ge diodes.
(Jul '19 – 4M)
7. Define following diode parameters: (i) Static resistance (ii) Dynamic resistance (iii) Knee voltage (iv) Forward voltage drop (v) Maximum forward current (vi) Reverse saturation current (vii) Reverse breakdown voltage (viii) Peak inverse voltage (PIV) (ix) Maximum power rating
(Jan '20 – 5M, Jan '17 – 5M, MQP '15 – 6M)
8. What is diode? Explain the various parameters of diode in brief.
(Sep '20 – 6M)
9. What is semiconductor diode? Explain the different equivalent circuits of diode.
(Jul '19 – 6M)
10. Explain the (i) Ideal diode approximation (ii) Practical diode approximation (iii) Piecewise linear approximation of diode.
(Jul '18 – 6M)
11. What is a rectifier?
(Jan '20, Jan '16)
12. What is rectifier circuit? Explain the classification of the rectifier.
(Jul '19)
13. With a neat circuit diagram, explain the working of a half-wave rectifier along with relevant waveforms.
(Jul '19 – 6M, Jul '17 – 6M, Jul '15 – 7M, Jan '15 – 7M, MQP '15 – 6M)
14. With a neat circuit diagram and waveforms, explain the working of half-wave rectifier and derive the expression for average load current.
(MQP '18 – 8M)
15. Derive the expressions for I_{dc} , V_{dc} , I_{rms} , V_{rms} , regulation, efficiency η_r , ripple factor γ and PIV of a half-wave rectifier.
(Jul '19 – 8M)
16. Show that the ripple factor of a half wave rectifier is 1.21 and maximum efficiency is 40.5%.
(Jan '19 – 6M, Jan '15)
17. With a neat circuit diagram, explain the working of a two diode (centre-tapped) full-wave rectifier along with relevant waveforms.

(Sep '20 – 8M, Jan '20 – 6M, Jul '19 – 6M, Jan '19 – 7M, MQP '18 – 8M, Jul '18 – 5M, Jan '18, Jul '17 – 8M, Jul '16 – 6M, Jan '16 – 8M, Jul '15 – 10M, MQP '14 – 8M)

18. With a neat circuit diagram and waveforms, explain the working of centre-tapped full-wave rectifier. Show that efficiency of full-wave rectifier is 81%. **(Jan '19 – 8M, Jan '18 – 10M)**
19. Define rectifier. Sketch a centre-tapped full-wave rectifier and derive the following. Show the appropriate waveforms. (i) Average Voltage (ii) Efficiency and (iii) Ripple factor
(MQP '18 – 8M)
20. Derive the expressions for I_{dc} , V_{dc} , I_{rms} , V_{rms} , regulation, efficiency η_r , ripple factor γ and PIV of a full-wave rectifier. **(Jul '18, Jan '18, Jul '15)**
21. Show that the maximum efficiency of a full-wave rectifier is 81.2%. **(Jan '18)**
22. What is ripple factor? Show that the ripple factor of a full-wave rectifier is 0.48.
(Jul '16 – 5M, MQP '14)
23. With a neat circuit diagram, explain the working of a bridge rectifier along with relevant waveforms. **(Sep '20 – 8M, Jan '20 – 8M, Jan '17 – 7M, Jan '16 – 6M)**
24. Explain with a neat circuit diagram and waveforms, the working of full-wave bridge rectifier. Show that the efficiency of full-wave bridge rectifier is 81%. **(Jan '20 – 9M)**
25. With a neat circuit diagram and waveforms, explain the working of full-wave bridge rectifier. Also derive V_{dc} and V_{rms} values for full wave rectifier. **(Jul '19 – 9M)**
26. Derive the expressions for I_{dc} , V_{dc} , I_{rms} , V_{rms} , regulation, efficiency η_r , ripple factor γ and PIV of a bridge rectifier.
27. What is the need for a capacitive filter? Explain. **(Sep '20, Jan '16)**
28. Explain briefly the operation of a capacitive filter circuit. **(MQP '18 – 6M, Jul '17 – 4M)**
29. What is the need for a capacitive filter? Explain the operation of half-wave rectifier with capacitor filter with neat circuit diagram and waveforms.
(Sep '20 – 6M, Jan '20 – 6M, Jan '19 – 6M)
30. Explain the operation of full-wave rectifier with capacitor filter. **(Jul '19 – 5M)**
31. Briefly explain choke–capacitor filter circuit.
32. Name the junction breakdowns in diodes. Explain them briefly. **(Jul '16 – 5M)**
33. Distinguish between Zener and Avalanche breakdown. **(Jul '15 – 6M)**
34. Write a note on voltage regulator circuit. **(Jan '17 – 5M)**
35. What is Zener diode? With neat circuit diagrams, explain the operation of a voltage regulator with and without load. **(Sep '20 – 6M, MQP '18 – 8M, Jan '18 – 5M, Jul '17 – 6M)**
36. With a neat diagram, explain how Zener diode can be used for voltage regulation (with no load and with load). Give detailed mathematical analysis.
(Sep '20 – 6M, Jan '20 – 8M, Jul '19 – 8M, Jan '19 – 6M, MQP '18 – 6M, Jul '18 – 5M, Jan '18 – 5M, Jul '16 – 5M, MQP '15 – 6M)

37. Explain the terms line regulation and load regulation with respect to voltage regulator.

(Jan '19 - 8M, Jan '16 - 6M, Jan '15 - 6M)

38. A silicon diode has $I_S = 10 \text{ nA}$ operating at 25°C . Calculate I_D for a forward bias of 0.6 V .

(Sep '20 - 6M, MQP '18 - 4M)

39. Calculate the output voltage V_o in the following circuit.

(Jul '18 - 2M)

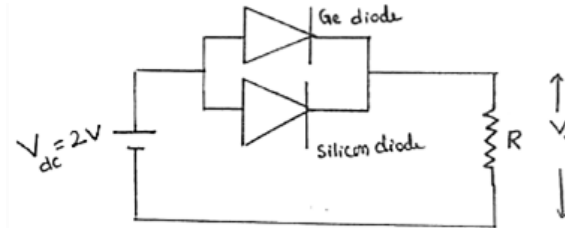

40. A diode circuit shown below has $E = 1.5\text{V}$, $R_1 = 10 \text{ ohm}$. By assuming $V_f = 0.7\text{V}$, calculate I_f for (i) $r_d = 0$ (ii) $r_d = 0.25 \text{ ohm}$

(MQP '18 - 6M)

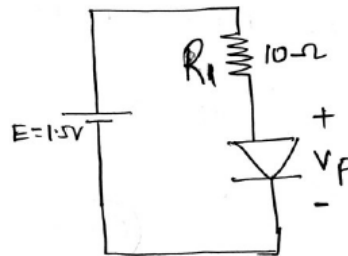

41. Find the value of the series resistance R required to drive a forward current of 1.25 mA through a Germanium diode from a 4.5 V battery. Write the circuit diagram showing all the values.

(Jan '19 - 4M, Jul '15 - 4M)

42. A half-wave rectifier circuit is supplied from secondary transformer voltage of 108.423 V to a resistive load of $10 \text{ k}\Omega$. The diode forward resistance is 10Ω . Calculate the maximum, average, RMS value of current, DC output voltage and efficiency of transformer.

(Jan '20 - 6M)

43. In a half wave rectifier, the input is from 30 V transformer. The load and diode forward resistances are 100Ω and 10Ω respectively. Calculate the I_{dc} , I_{rms} , P_{dc} , P_i , η , PIV and regulation factor.

(Jul '17 - 8M)

44. A half wave rectifier is fed from a supply 230 V , 50 Hz with a step-down transformer of ratio $3:1$. Resistive load connected is $10 \text{ k}\Omega$. The diode forward resistance is 75Ω and transformer secondary is 10Ω . Calculate the DC load current, DC load voltage, efficiency and ripple factor.

(MQP '18 - 6M, Jan '18 - 6M)

45. A transformer with $10:1$ turns ratio is connected to a half wave rectifier with supply voltage of $220 \sin 210t$. If load and forward resistances are 500Ω and 10Ω respectively, calculate the average output voltage, dc output power, ac input power, rectification efficiency and peak inverse voltage.

(Jan '18 - 5M)

46. The input to a half wave rectifier is given through a $10:1$ transformer from a supply given by $230 \sin 314t \text{ V}$. If $R_f = 50 \Omega$ and $R_L = 500 \Omega$, determine DC load voltage, RMS load voltage, rectification efficiency, DC power delivered to the load.

(Jan '17 - 8M)

47. A full wave rectifier with a transformer secondary voltage $60\text{V} - 0 - 60\text{V}$, supplies a load resistance $R_L = 2\text{ k}\Omega$. The diode forward resistance R_f is $10\ \Omega$. Determine (i) maximum value of current in conducting diodes (ii) dc value of current through R_L (iii) output dc voltage and (iv) PIV across each diode. **(Jan '20 - 7M)**
48. A full wave rectifier uses 2 diodes having internal resistance of $10\ \Omega$ each. The transformer RMS secondary voltage from centre to each end is 200 V . Find I_m , I_{dc} , I_{rms} and V_{dc} if the load is $800\ \Omega$. **(Jan '20 - 6M)**
49. A full wave rectifier uses 2 diodes having internal resistance of $20\ \Omega$ each. The transformer RMS secondary voltage from centre to each end is 50 V . Find I_m , I_{dc} , I_{rms} and V_{dc} if the load is $980\ \Omega$. **(Jul '19 - 6M)**
50. A full wave rectifier supplies a load of $1000\ \Omega$. The ac voltage applied to it is $200 - 0 - 200\text{ V}$ (rms). Calculate (i) I_{dc} (ii) I_{rms} (iii) efficiency (η). Assume $R_f = 0\ \Omega$. **(Jul '19 - 6M)**
51. A full wave rectifier has a load of $1\text{ k}\Omega$. The ac voltage applied to the diode is $200 - 0 - 200\text{ V}$. If diode resistance is neglected, calculate (i) average dc current (ii) average dc voltage. **(Jan '16 - 4M)**
52. A single phase full wave rectifier supplies power to a $1\text{ k}\Omega$ load. The AC voltage applied to the diode is $300 - 0 - 300\text{ V}$. If diode resistance is $25\ \Omega$ and that of the transformer secondary negligible, determine load current, average load voltage and rectification efficiency. **(Jan '15 - 6M)**
53. A full wave bridge rectifier with an input of 100 V (rms) feeds a load of $1\text{ k}\Omega$. $V_T = 0.7\text{ V}$
- If the diodes employed are of silicon, what is the dc voltage across the load?
 - Determine the PIV rating of each diode.
 - Determine the maximum current that each diode conducts and the diode power rating.
- (MQP '18 - 6M)**
54. The input to the full wave rectifier is $v(t) = 200 \sin 50t$. If R_L is $1\text{ k}\Omega$ and forward resistance of diode is $50\ \Omega$, find:
- D.C current through the circuit
 - The A.C (rms) value of current through the circuit
 - The D.C output voltage
 - The A.C power input
 - The D.C power output
 - Rectifier efficiency.
- (MQP '15 - 6M)**
55. In a full wave rectifier, the input is from $30 - 0 - 30\text{ V}$ transformer. The load and diode forward resistances are $100\ \Omega$ and $10\ \Omega$ respectively. Calculate the average voltage, dc output power, ac input power, rectification efficiency and percentage regulation. **(MQP '14 - 5M)**
56. The input voltage applied to the primary of a 4:1 step down transformer of a full wave centre tap rectifier is 230 V , 50 Hz . If the load resistance is $600\ \Omega$ and forward resistance is $20\ \Omega$, determine the following:
- dc output power
 - Rectification efficiency
 - PIV
- (Jan '18 - 6M)**

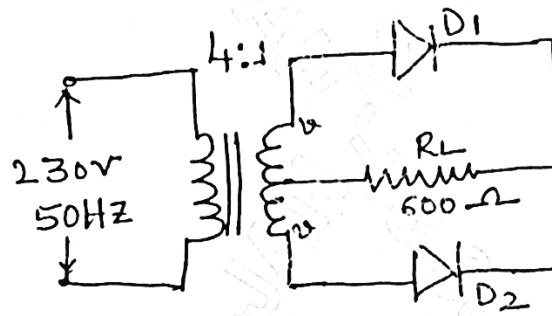

57. A 4.3 V Zener diode is connected in series with $820\ \Omega$ resistor and DC supply voltage of 12 V. Find the diode current and the power dissipation. **(Jul '16 - 5M)**
58. A 9 V reference source is to use a series connected Zener diode and a resistor connected to 30 V supply. If Zener diode with $V_Z = 9\ \text{V}$, $I_{ZT} = 20\ \text{mA}$ is selected, then determine the value of series resistance and calculate the circuit current when the supply voltage drops to 27 V. **(Jan '20 - 5M)**
59. Design a 9 V DC reference source consisting of a Zener diode and series connected resistor to operate from a 24 V supply [$I_{ZT} = I_Z = 20\ \text{mA}$]. **(Jan '19 - 5M)**
60. A Zener diode has a breakdown voltage of 10 V. It is supplied from a voltage source varying between 20 – 40 V in series with a resistance of $820\ \Omega$. Using an ideal Zener model, obtain the minimum and maximum Zener currents. **(MQP '18 - 6M)**
61. For the circuit shown in the figure, find current and voltages in the circuit for $R_L = 450\ \Omega$, $V_Z = 10\ \text{V}$. **(Jan '19 - 4M)**



62. For a Zener regulator shown in the figure, calculate the range of input voltage for which output will remain constant.

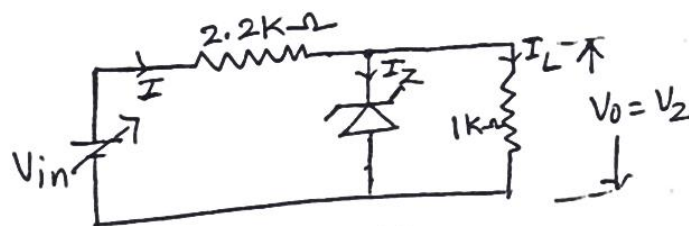

$$V_Z = 6.1\ \text{V}, I_{Z\min} = 2.5\ \text{mA}, I_{Z\max} = 25\ \text{mA}, r_Z = 0\ \Omega.$$

(Jul '16 - 4M)

63. Design Zener voltage regulator for the following specifications:
Input Voltage = $10\ \text{V} \pm 20\%$, Output Voltage = 5 V, $I_L = 20\ \text{mA}$, $I_{Z\min} = 5\ \text{mA}$ and $I_{Z\max} = 80\ \text{mA}$. **(MQP '14 - 5M)**
64. Design a Zener diode voltage regulator circuit to meet the following specifications:
 $I_L = 20\ \text{mA}$, $V_o = 5\ \text{V}$, $P_Z = 500\ \text{mW}$, $V_i = 12\ \text{V} \pm 2\ \text{V}$ and $I_{Z\min} = 8\ \text{mA}$. **(Jul '19 - 5M)**
65. Design the Zener regulator for the following specifications:
Output voltage = 5 V, Load current = 20 mA, Zener voltage $P_{Z(\min)} = 500\ \text{mW}$ and Input voltage = $12\ \text{V} \pm 3\ \text{V}$. **(Jan '19 - 5M)**

Special-Purpose Diodes and 7805 Voltage Regulators

1. Write a note on photodiode and mention its applications.
2. Explain the working of photodiode. *(Jan '20 – 5M, Jul '19 – 5M)*
3. Write a short note on photodiode. *(MQP '18 – 3M)*
4. Explain VI characteristics of photodiode and its operation. *(Jan '19 – 4M)*
5. Explain photodiode and LED in brief. *(Sep '20 – 6M)*
6. Explain the principle of operation of a light-emitting diode (LED) and mention its applications.
7. Write a short note on light-emitting diode. *(MQP '18 – 4M)*
8. Write a short note on photocoupler. *(MQP '18 – 4M)*
9. Explain the operation of 7805 fixed IC voltage regulator. *(Sep '20 – 6M, MQP '18 – 6M)*
10. Explain the functional block diagram of 78XX series voltage regulator. *(Jul '19 – 6M)*
11. Explain the features of LM7805 fixed regulator. *(MQP '18 – 6M)*

Module – 2

Field-Effect Transistors

1. Explain the construction and operation of JFET with necessary diagram. *(MQP '18 – 7M)*
2. Explain the basic structure and operation of JFET with neat diagrams. *(Jan '19 – 8M)*
3. Explain the construction, working and characteristics of N-channel JFET. *(Jan '20 – 9M, Jul '19 – 9M)*
4. Explain construction and operation of N-channel JFET. Draw transfer and drain characteristics. *(Sep '20 – 8M)*
5. Explain the construction and operation of a P-channel JFET. *(MQP '18 – 8M)*
6. Explain the drain and transfer characteristics of JFET with neat circuit diagram. *(Jan '19 – 8M)*
7. Explain the characteristics of N-channel JFET. *(MQP '18 – 8M)*
8. Explain the characteristics of P-channel JFET.
9. With neat diagrams, explain the characteristics of JFET and write the equation of square law.
10. Explain the construction, working and characteristics of enhancement type MOSFET. *(Jan '20 – 9M, Jul '19 – 9M)*
11. Explain the construction and working of N-channel enhancement type MOSFET.
12. Explain the construction and working of P-channel enhancement type MOSFET. *(MQP '18 – 8M)*
13. Explain the operation of an enhancement MOSFET with neat circuit diagram. *(Jan '19 – 6M)*

14. Explain construction and operation of N-channel depletion MOSFET. **(Sep '20 – 8M)**
15. Explain construction and operation of P-channel depletion MOSFET.
16. What is MOSFET? Explain D-MOSFET and E-MOSFET transfer characteristics. **(MQP '18 – 8M)**
17. With neat diagram, explain the characteristics of an enhancement type MOSFET. **(MQP '18 – 8M)**
18. With neat diagrams, explain the characteristics of MOSFET.
19. Explain CMOS as an inverter with neat circuit diagram. Give its equivalent circuit and its advantages. **(Jan '19 – 8M)**
20. With a neat circuit diagram, explain the operation of a CMOS inverter. **(Sep '20 – 6M, Jan '20 – 6M, Jul '19 – 6M, MQP '18 – 7M)**
21. An N-channel JFET has $I_{DSS} = 8 \text{ mA}$ and $V_P = -4 \text{ V}$, calculate I_D at $V_{GS} = -1 \text{ V}$ and $V_{GS} = -2 \text{ V}$. **(Sep '20 – 6M)**
22. For an N-channel JFET, if $I_{DSS} = 9 \text{ mA}$ and $V_P = -6 \text{ V}$, calculate I_D at $V_{GS} = -4 \text{ V}$ and V_{GS} at $I_D = 3 \text{ mA}$. **(Jan '20 – 5M)**
23. For an N-channel JFET, if $I_{DSS} = 8 \text{ mA}$ and $V_P = -5 \text{ V}$, calculate I_D at $V_{GS} = -3 \text{ V}$ and V_{GS} at $I_D = 3 \text{ mA}$. **(Jul '19 – 5M)**
24. For a JFET, I_{DSS} of 9 mA for $V_{GS(off)} = -8 \text{ V}$ (max). Determine drain current for $V_{GS} = -4 \text{ V}$. **(Jan '19 – 4M)**
25. A certain JFET has I_{GSS} of -2 nA for $V_{GS} = -20 \text{ V}$. Determine the input resistance. **(MQP '18 – 4M)**
26. For E-MOSFET, determine the value of I_D , if $I_{D(ON)} = 4 \text{ mA}$, $V_{GS(ON)} = 6 \text{ V}$, $V_T = 4 \text{ V}$ and $V_{GS} = 8 \text{ V}$. **(Jan '20 – 5M, MQP '18 – 4M)**

Silicon Controlled Rectifiers

1. What is SCR? Explain the working of SCR using two-transistor model. **(Sep '20 – 8M, Jan '20 – 6M, Jul '19 – 6M, MQP '18 – 6M)**
2. Draw and explain the operation of SCR using two-transistor equivalent circuit. **(MQP '18 – 8M)**
3. Using the two-transistor model, explain the switching action of SCR.
4. What is commutation in SCR? Explain two types of commutation. **(Jul '19 – 5M)**
5. Explain natural and forced commutation turn off methods of SCR. **(Sep '20 – 6M)**
6. Draw and explain the V-I characteristics of SCR. **(Jan '19 – 6M, MQP '18 – 6M)**
7. Explain phase control application of SCR. **(MQP '18 – 6M)**

Module – 3

Operational Amplifiers and Applications

1. What is an op-amp? Mention the applications of op-amp.
(Sep '20, Jan '20, Jul '19, Jul '18, Jan '18, Jan '17, Jan '16, MQP '15, MQP '14)
2. Describe the characteristics of basic op-amp. List out its ideal characteristics.
(MQP '18 – 8M)
3. What is op-amp? List out the ideal and practical characteristics of op-amp. (Jan '19 – 7M)
4. List and explain the characteristics of an ideal op-amp.
(Sep '20 – 6M, Jan '20 – 6M, Jul '19 – 6M, Jan '19 – 5M, MQP '18 – 8M, Jul '18 – 5M, Jan '18 – 6M, Jul '17 – 4M, Jan '17 – 6M, Jul '16 – 7M, Jan '16 – 4M, Jul '15 – 6M, Jan '15 – 5M, MQP '15, MQP '14 – 6M)
5. Explain the internal block diagram of an operational amplifier. (Jan '19 – 6M, Jul '16)
6. With neat circuit diagrams, explain the different input modes of an op-amp.
(Jan '20 – 6M, Jan '19 – 6M)
7. Explain the following terms related to op-amp: (i) Open loop voltage gain (ii) Common mode gain (iii) CMRR (iv) Maximum Output Voltage Swing (v) Input Offset Voltage (vi) Input Offset Current (vii) Input bias current (viii) Input impedance (ix) Output impedance (x) Slew rate (xi) PSRR/Supply voltage rejection ratio (xii) Virtual ground.
(Sep '20 – 8M, Jan '20 – 8M, Jul '19 – 8M, Jan '19 – 8M, MQP '18 – 10M, Jul '18 – 6M, Jan '18 – 5M, Jul '16 – 5M, Jan '16 – 6M)
8. Write a short note on virtual ground concept of an op-amp. (Jan '18 – 6M)
9. Explain the operation of an op-amp as an (i) Inverting amplifier (ii) Non inverting amplifier. Derive an expression for the output voltage and voltage gain.
(Jan '19 – 8M, Jan '18 – 4M, Jul '17 – 6M, Jan '17 – 6M, Jul '16 – 5M)
10. Explain the operation of an op-amp as an inverting amplifier with neat diagram and waveforms. Derive the expression for output voltage.
(Jan '20 – 6M, MQP '18 – 8M, Jul '18 – 7M, Jan '18 – 5M)
11. Explain the operation of an op-amp as a non-inverting amplifier with neat diagram and waveforms. Derive the expression for output voltage.
(Sep '20 – 8M, Jan '20 – 7M, Jan '19 – 6M, MQP '18 – 6M, Jul '18 – 4M)
12. With neat circuit and necessary equations, explain the voltage follower circuit using op-amp. Mention its important properties.
(Jan '20 – 4M, Jul '19 – 4M, MQP '18 – 4M, Jan '18, Jul '17 – 6M, Jan '17 – 6M, Jan '16 – 4M, Jul '15 – 5M, MQP '15 – 6M, MQP '14)
13. Explain how an op-amp can be used as (i) Inverting summer (ii) Non inverting summer.
(Jan '18, Jul '17, MQP '14)
14. Derive an expression for the output voltage of an inverting summer.
(Jan '20 – 6M, Jul '19, MQP '18 – 6M)

15. With neat circuit, explain the operation of three input adder circuit. Derive expression for V_o . **(Sep '20 – 8M)**
16. Draw the three input inverting summer circuit and derive an expression for its output voltage.
(Jan '19 – 5M, MQP '18 – 8M, Jan '18 – 5M, Jan '16 – 5M, MQP '15 – 5M)
17. Show with a circuit diagram, how an op-amp can be used as a subtractor. Derive an expression for the output voltage. **(Sep '20 – 7M, Jul '19 – 4M, Jan '19 – 8M, Jan '17 – 8M)**
18. Explain difference amplifier using op-amp. **(Sep '20 – 6M)**
19. With a neat circuit diagram, show how an op-amp can be used as an integrator. Derive the expression for output voltage.
(Sep '20 – 6M, Jan '20 – 4M, Jul '19 – 5M, Jan '19 – 5M, MQP '18 – 6M, Jul '18 – 5M, Jan '18 – 4M, Jul '17 – 4M, Jan '17, Jul '16 – 6M, Jan '16 – 6M, MQP '14)
20. With a neat circuit diagram, show how an op-amp can be used as a differentiator. Derive the expression for output voltage. **(Jul '19 – 6M, MQP '18 – 6M, Jan '18, Jan '17, Jan '15 – 5M)**
21. Define the following and derive the expression for its output voltage
i) Differentiator ii) Integrator **(Jan '20 – 6M)**
22. With a neat circuit diagram, derive an equation for op-amp application as
i) Inverting amplifier ii) Non-inverting amplifier iii) Inverting 2-input summer
iv) Subtractor v) Integrator vi) Differentiator **(Jul '19 – 12M)**
23. With a neat circuit diagram, show how an op-amp can be used as a comparator.
24. A certain op-amp has an open loop differential voltage gain of 1,00,000 and CMRR = 4,00,000. Determine common mode gain and express CMRR in decibels. **(Sep '20 – 6M)**
25. A certain op-amp has an open loop voltage gain of 1,00,000 and a common mode gain of 0.2. Determine the CMRR and express it in decibels. **(MQP '18 – 4M)**
26. An op-amp has an open loop voltage gain of 10^4 and a common mode voltage gain of 0.1. Express the CMRR in dB. **(Jul '16 – 8M)**
27. An inverting amplifier has $R_1 = 20 \text{ k}\Omega$, $R_f = 100 \text{ k}\Omega$. Find the output voltage, input resistance and input current for an input voltage of 1V. **(Sep '20 – 4M)**
28. An op-amp has a slew rate of $0.8 \text{ V}/\mu\text{sec}$. What is the maximum amplitude of undistorted sine wave that the op-amp can produce at a frequency of 40 kHz? What is the maximum frequency of the sine wave that op-amp can reproduce if the amplitude is 3 V?
(Sep '20 – 4M)
29. A non-inverting amplifier has closed loop gain of 25. If input voltage $V_i = 10 \text{ mV}$, $R_f = 10 \text{ k}\Omega$, determine the value of R_1 and output voltage V_o . **(Sep '20 – 6M)**
30. Find the gain of a non-inverting amplifier if $R_f = 10 \text{ k}\Omega$ and $R_1 = 1 \text{ k}\Omega$.
(Sep '20, Jan '16 – 6M)
31. Find the gain and output voltage for a non-inverting amplifier using op-amp when input voltage is i) 0.5 V ii) -3V **(Jan '20 – 2M)**

32. A non-inverting amplifier circuit has an input resistance of $10\text{ k}\Omega$ and feedback resistance $60\text{ k}\Omega$ with load resistance of $47\text{ k}\Omega$. Draw the circuit. Calculate the output voltage, voltage gain, load current when the input voltage is 1.5 V . **(Jan '19 - 6M, MQP '18 - 8M)**
33. Design an inverting and non-inverting operational amplifier to have a gain of 15. **(Jan '18 - 5M)**
34. Calculate the output voltage of a three input inverting summing amplifier, given $R_1 = 200\text{ k}\Omega$, $R_2 = 250\text{ k}\Omega$, $R_3 = 500\text{ k}\Omega$, $R_f = 1\text{ M}\Omega$, $V_1 = -2\text{V}$, $V_2 = -1\text{V}$ and $V_3 = +3\text{V}$. **(Jan '19 - 5M, Jul '16 - 4M)**
35. Design an op-amp circuit to obtain output expression as $V_o = -[V_1 + 3V_2 + 5V_3]$. **(Jul '19 - 6M)**
36. Design an adder circuit using op-amp to obtain an output expression $V_o = -[0.1V_1 + 0.5V_2 + 20V_3]$, where V_1 , V_2 and V_3 are inputs. Select $R_f = 10\text{ k}\Omega$. **(Jul '19 - 7M, Jul '18 - 6M)**
37. Design an adder circuit using op-amp to obtain an output voltage, $V_o = -[2V_1 + 3V_2 + 5V_3]$. Assume $R_f = 10\text{ k}\Omega$. **(Jan '20 - 6M, MQP '18 - 6M, Jan '18 - 6M)**
38. Design an op-amp circuit that will produce an output equal to $-[4V_1 + V_2 + 0.1V_3]$. **(Jan '18 - 6M)**
39. Design an inverting summing circuit with feedback $R_f = 100\text{ k}\Omega$ using an op-amp to generate the output $V_o = -[3V_1 + 4V_2 + 5V_3]$. **(Jan '17 - 6M)**
40. Design an adder circuit using op-amp to obtain an output voltage of $V_o = -[0.1V_1 + 0.5V_2 + 2V_3]$, where V_1 , V_2 and V_3 are input voltages. Draw the circuit diagram. **(Jul '15 - 8M)**
41. The input to the basic differentiator circuit is a sinusoidal voltage of peak value of 10 mV and frequency 1.5 kHz . Find the output if $R_f = 100\text{ k}\Omega$ and $C_1 = 1\mu\text{F}$. **(MQP '18 - 4M)**
42. Calculate the output voltage for the circuit shown in the figure. **(Jan '20 - 8M)**

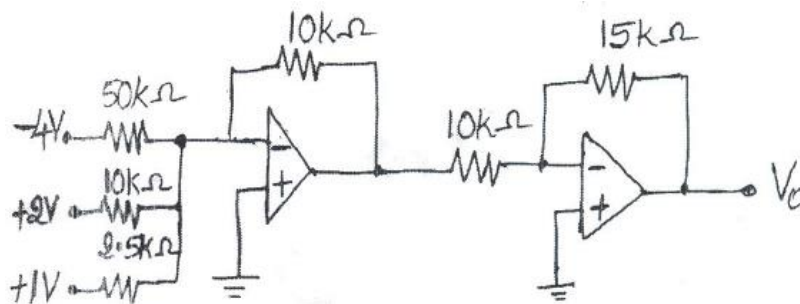

43. Find the output of the op-amp circuit shown in the figure below. **(Jul '19 - 6M)**

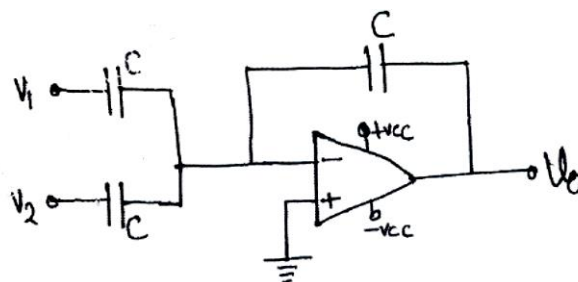

44. For an op-amp circuit shown in the figure, find the output V_{O1} and V_{O2} . Also write the function of each op-amp used. (Jan '19 - 6M, MQP '18 - 6M)

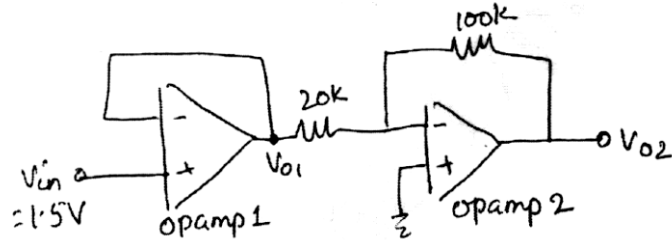

45. Find the output of the following op-amp circuit. (Jul '18 - 5M)

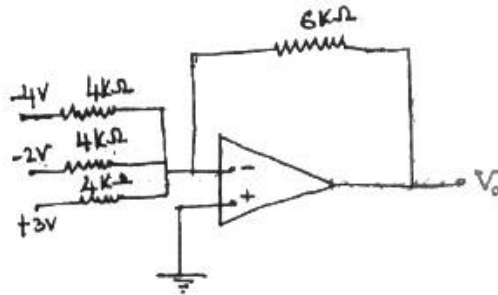

46. Find the output of the following op-amp circuit. (Jul '17 - 5M, Jan '17 - 5M, MQP '14 - 5M)

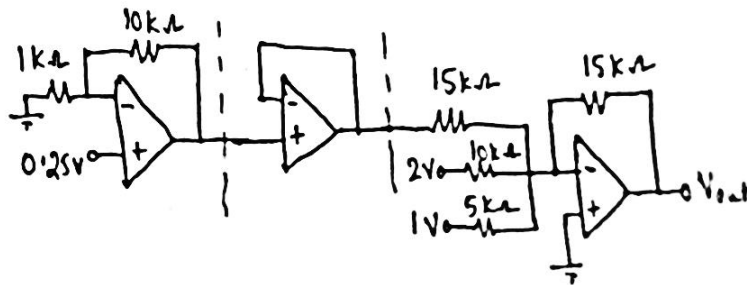

47. Find the output of the following op-amp circuit. (Jul '17 - 5M)

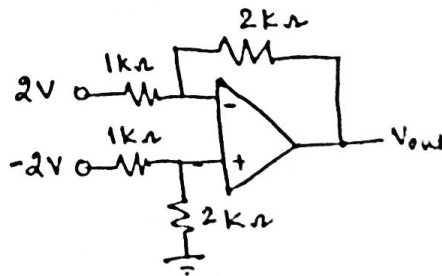

48. Determine V_0 for the circuit shown below. (Jul '16 - 5M)

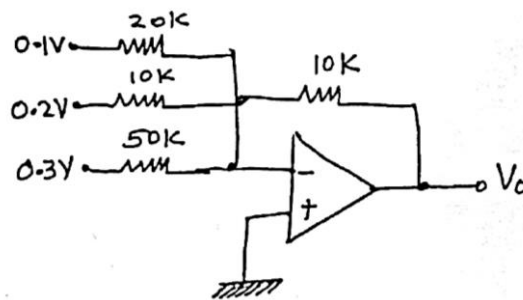

49. For the circuit shown in the figure, calculate the output voltage.

(Jan '16 - 4M)

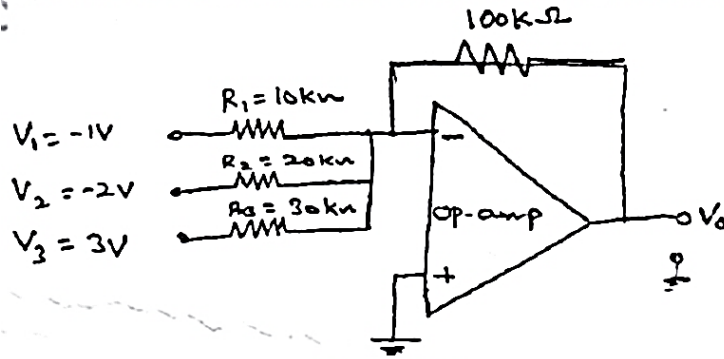

50. Write expression for output voltage at points A, B, C, D and E as shown in figure.

(Jan '15 - 10M)

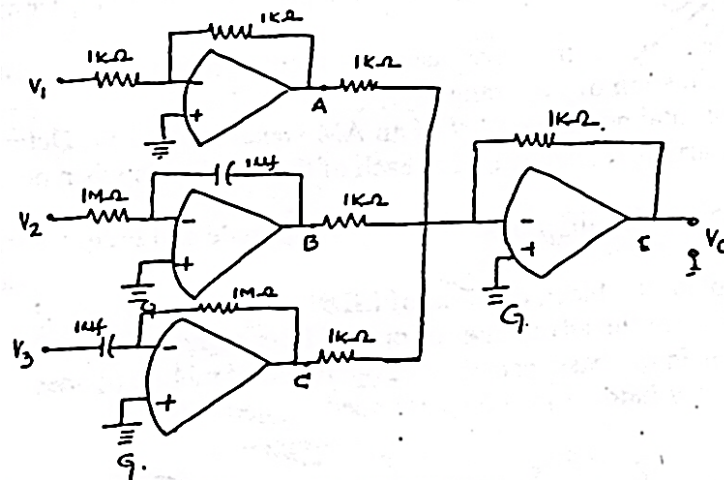

51. Find the output of the following op-amp Circuit

(MQP '14 - 5M)

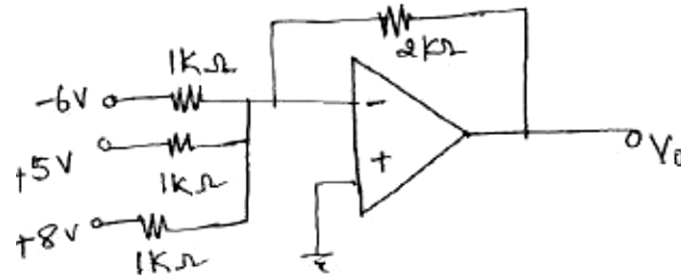

Module - 4

BJT Applications

1. What is an amplifier? Explain the operation of transistor amplifier circuit.

(MQP '18 - 8M)

2. With neat circuit diagram, explain how transistor is used as a voltage amplifier. Derive an equation for voltage gain A_v .

(Sep '20 - 8M, Jan '20 - 8M, Jul '19 - 6M, Jan '19 - 8M)

3. Briefly explain how a transistor is used as an electronic switch.

(MQP '18 - 6M)

4. Explain the operation of BJT (transistor) as an amplifier and as a switch.

(MQP '18 - 10M)

5. With a neat circuit diagram, explain how transistor can be used to switch an LED ON/OFF and give the necessary equations. **(Jan '19 - 8M)**
6. Determine the value of the collector resistor in an npn transistor amplifier with $\beta_{dc} = 250$, $V_{BB} = 2.5\text{ V}$, $V_{CC} = 9\text{ V}$, $V_{CE} = 4\text{ V}$ and $R_B = 100\text{ k}\Omega$.
7. In a transistor amplifier circuit, determine the voltage gain and the ac output voltage if $V_b = 100\text{ mV}$, $R_C = 1\text{ k}\Omega$ and $r'_e = 50\ \Omega$.
8. The transistor in CE configuration is shown in figure, with $R_C = 1\text{ k}\Omega$ and $\beta_{dc} = 125$. Determine (i) V_{CE} at $V_{in} = 0\text{ V}$ (ii) $I_{B(\min)}$ to saturate the collector current (iii) $R_{B(\max)}$ when $V_{in} = 8\text{ V}$. $V_{CE(\text{sat})}$ can be neglected. **(Jan '20 - 4M)**

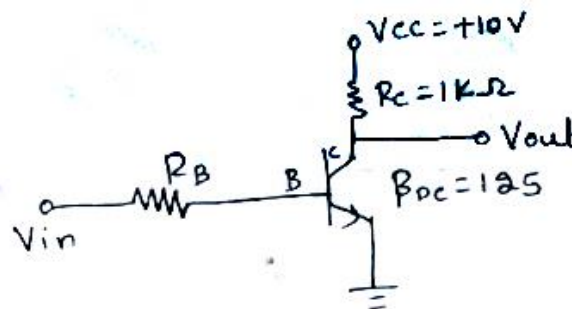

9. The transistor in common emitter configuration is shown in figure, with $R_C = 10\text{ k}\Omega$ and $\beta_{dc} = 200$. Determine (i) V_{CE} at $V_{in} = 0$ (ii) $I_{B(\min)}$ to saturate the collector current (iii) $R_{B(\max)}$ when $V_{in} = 5\text{ V}$. $V_{CE(\text{sat})}$ can be neglected. **(Jan '19 - 4M)**

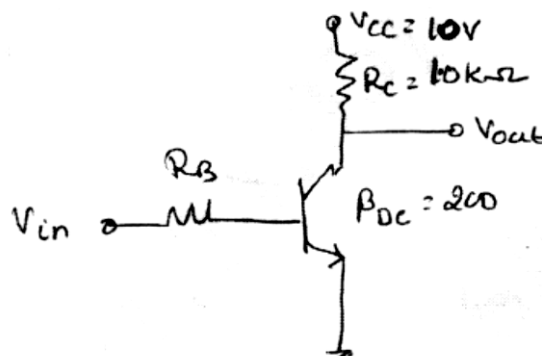

Feedback Amplifiers and Oscillators

1. What is feedback amplifier? What are the properties of negative feedback amplifier? **(Jul '19 - 6M)**
2. What is a feedback amplifier? Briefly explain different types of feedback amplifiers. **(MQP '18 - 6M)**
3. Define feedback amplifier. With necessary diagram and equation explain the different types of feedback. **(MQP '18 - 12M)**
4. List the advantages of negative feedback in an amplifier. Explain the voltage series feedback amplifier. Show that the gain bandwidth product for a feedback amplifier is constant. **(MQP '18 - 10M)**

5. Mention types of feedback amplifier. With block diagram, explain voltage series feedback amplifier. **(Sep '20 – 6M)**
6. Draw and explain the operation of a voltage series feedback amplifier circuit and derive an expression for its voltage gain A_v with feedback. **(Jan '20 – 4M, Jul '19 – 6M, Jan '19 – 4M, MQP '18 – 6M)**
7. With necessary equations, explain how gain is stabilized by using feedback.
8. Explain the Barkhausens' criteria for oscillations. **(MQP '18 – 6M)**
9. What is an oscillator? Write a note on classification of oscillators.
10. What is phase shift oscillator? Explain with circuit, RC phase shift oscillator. **(Sep '20 – 8M)**
11. Explain RC phase shift oscillator with circuit diagram and necessary equations. **(Jan '20 – 8M, Jan '19 – 8M, MQP '18 – 6M)**
12. With a neat circuit diagram, explain the working of Wien bridge oscillator. **(Jan '20 – 8M, Jul '19 – 8M)**
13. Define an oscillator. Derive the equation for Wien bridge oscillator. **(MQP '18 – 8M)**
14. Write a note on IC 555 timer.
15. Explain the operation of IC-555 timer as an astable oscillator with neat circuit diagram and necessary equations. **(Jan '20 – 8M, Jul '19 – 8M, Jan '19 – 8M, MQP '18 – 8M)**
16. Explain with circuit, astable multivibrator using IC 555. **(Sep '20 – 6M)**
17. A negative feedback amplifier has gain $A = 1000$ and bandwidth of 200 kHz. Calculate gain and bandwidth with feedback if feedback factor $\beta = 20\%$. **(Sep '20 – 6M)**
18. An amplifier has a high frequency response described by $A = \frac{A_0}{1+(j\omega/\omega_2)}$ wherein $A_0 = 1000$, $\omega_2 = 10^4$ rad/s. Find the feedback factor which will raise the upper corner frequency ω_2 to 10^5 rad/s. What is the corresponding gain of the amplifier? Find also the gain bandwidth product in this case. **(MQP '18 – 4M)**
19. Design a RC phase shift oscillator for a frequency of 1 kHz. Draw the circuit diagram with designed values. **(Jul '19 – 6M)**
20. The frequency sensitivity arms of the Wein bridge oscillator uses $C_1 = C_2 = 0.01 \mu\text{F}$ and $R_1 = 10 \text{ k}\Omega$ while R_2 is kept variable. The frequency is to be varied from 10 kHz to 50 kHz by varying R_2 . Find the minimum and maximum values of R_2 . **(MQP '18 – 4M)**
21. An astable multivibrator circuit has $R_1 = 6.8 \text{ k}\Omega$, $R_2 = 4.7 \text{ k}\Omega$, $C = 0.1 \mu\text{F}$. Calculate frequency of oscillation and duty cycle. **(Sep '20 – 6M)**

Module – 5

Digital Electronics Fundamentals

1. Compare analog and digital signal. **(Jan '19 – 4M)**
2. What is Boolean algebra? Explain the basic laws of Boolean algebra. **(Sep '20 – 6M)**

3. State and prove DeMorgan's theorem.
(Jan '20 - 6M, Jan '19 - 4M, Jan '18 - 5M, Jul '17 - 6M, Jan '17 - 5M, Jul '16 - 4M, Jan '16 - 6M, MQP '15 - 8M)
4. State and prove DeMorgan's theorem for 2 variables.
(Sep '20 - 8M, Jul '18 - 4M, Jan '18 - 8M, Jan '16 - 4M)
5. State and prove DeMorgan's theorem for 3 variables.
(Jan '20 - 4M, Jul '19 - 4M, Jul '15 - 6M, MQP '14 - 4M)
6. State and prove DeMorgan's theorem for 4 variables. **(Jan '19 - 8M)**
7. State DeMorgan's theorem for 4 variables and prove by the method of perfect induction.
(Jan '15 - 6M)
8. With the help of switching circuit, input/output waveforms and truth table, explain the operation of a NOT Gate. **(MQP '14 - 5M)**
9. Write the logical symbol, truth table and Boolean expressions of all the logic gates: (AND, OR, NOT, NOR, NAND, EX-OR, EX-NOR). **(Jan '19 - 9M)**
10. Explain the basic gates AND, OR and NOT gates with truth tables. **(Jul '17 - 6M)**
11. Write the symbol and truth table of the following gates:
(i) AND (ii) NOR (iii) XOR (iv) NAND **(Jul '19 - 7M)**
12. Write symbol and truth tables of AND, OR, EX-OR and NOT gates. **(Jul '17 - 8M)**
13. With the help of a diode switching circuit and truth table, explain the operation of (i) OR gate (ii) AND gate.
(Jan '18 - 6M, Jul '16 - 8M, Jan '16 - 4M, Jul '15 - 6M, Jan '15 - 4M)
14. Explain the operation of (i) NOR gate (ii) NAND gate (iii) XOR gate (iv) XNOR gate.
15. Write the symbol, truth table and final expression for NAND and EX-OR gate (for two inputs). **(Jul '16 - 4M)**
16. Design a logic circuit, symbol and truth table of exclusive - OR gate. **(Jan '15 - 4M)**
17. Draw the symbol and write the truth table of the exclusive - NOR gate and EX-OR gate. Realize the same using basic gates also. **(Jan '20 - 6M)**
18. Which are the universal gates? Realize basic gates using universal gates. **(Jan '19 - 7M)**
19. What are universal gates? Realize AND and OR gates using universal gates.
(Jan '17 - 5M, Jan '16 - 2M, Jul '15 - 5M)
20. What is the speciality of NAND and NOR gates? Realize basic gates using (i) NAND gates only (ii) NOR gates only. **(Jul '17 - 4M, Jul '16 - 5M, Jan '15 - 4M)**
21. Realize OR and AND gates using only NAND gates and using only NOR gates. **(Jan '20 - 4M)**
22. Realize AND, OR and EX-OR gates using NAND gates. **(Jul '19 - 6M)**
23. Realize two input Ex-OR gate using only NAND gates.
(Jan '19 - 5M, Jul '18 - 5M, Jan '16 - 5M, MQP '14 - 5M)

24. Realize a two input exclusive NOR gate using only NAND gates, indicating the output at each of the gate. **(Jan '18 – 4M)**
25. Implement XOR gate using only NOR gates. **(Jul '19 – 5M, Jan '17 – 5M)**
26. Explain the half adder circuit and realize using basic gates. **(Jan '20 – 6M, Jul '17 – 4M)**
27. Write the truth table, design equations and circuit diagram of a half adder using logic gates. **(Jul '19 – 8M)**
28. Implement half adder using NAND gates. **(Sep '20 – 6M)**
29. Realize a half adder using (i) NAND gates only (ii) NOR gates only. **(Jan '19 – 4M, Jul '16 – 4M, MQP '15 – 5M)**
30. Explain full adder using truth table and expressions. Implement sum and carry expressions. **(Sep '20 – 6M)**
31. Design full adder circuit and implement it using basic gates. **(Jan '20 – 8M, Jan '19 – 10M)**
32. Explain the full adder circuit. **(MQP '18 – 6M, Jul '17 – 6M, MQP '15 – 5M)**
33. Explain the full adder circuit with truth table. Realize the circuit for sum and carry using logic gates (basic gates). **(Jan '18 – 8M, Jan '17 – 8M, Jan '16 – 7M, Jul '15 – 8M)**
34. Design a full adder and implement it using two half adders and write the equations for sum and carry. **(Jul '19 – 4M, Jan '19 – 8M, MQP '18 – 8M, Jan '18 – 8M, Jul '17 – 8M, Jan '17 – 5M, Jul '16 – 7M, Jan '16, Jan '15 – 6M, MQP '14 – 6M)**
35. Explain full adder and implement full adder using two half adders and an OR gate. **(Jan '20 – 8M)**
36. Explain full adder circuit with truth table. Realize the circuit for sum and carry using basic gates. Also write the diagram showing full adder using two half adders. **(Jul '18 – 10M)**
37. Write truth table of half adder and full adder. Realize the full adder using two half adders. **(Jul '19 – 7M)**
38. Realize a full adder using (i) NAND gates only (ii) NOR gates only. **(Jul '18 – 6M, Jul '15)**
39. With a logic diagram and truth table, explain the working of 2:1 multiplexer.
40. What is a multiplexer? Explain the working of 4:1 multiplexer. **(MQP '18 – 6M)**
41. What is multiplexer? Implement 8:1 multiplexer using basic gates. **(Jul '19 – 8M)**
42. What is a decoder? With a logic diagram and truth table, explain the working of 2:4 decoder.
43. With a logic diagram and truth table, explain the working of 3:8 decoder.
44. Explain the differences between combinational and sequential circuits.
45. What is a flip-flop? Distinguish between a latch and a flip-flop. **(Jul '19 – 2M, Jan '19 – 4M, Jul '18 – 5M, Jan '18 – 4M, Jul '17 – 4M, Jan '17 – 2M, Jul '16, Jan '16, Jul '15 – 4M, MQP '14 – 4M)**
46. What is a flip-flop? List out the applications of flip-flop. **(Sep '20 – 4M, Jan '19 – 4M)**

47. With the help of a logic diagram and truth table, explain the operation of an SR flip-flop.
(Jan '19 - 6M, Jan '18 - 6M, Jul '17 - 8M, Jul '16 - 5M, Jan '16 - 5M, Jul '15 - 6M, MQP '15 - 6M)
48. With the help of a logic diagram and truth table, explain the working of a clocked SR flip-flop.
(Sep '20 - 6M, Jan '20 - 6M, Jul '19 - 8M, Jan '19 - 7M, MQP '18 - 6M, Jul '18 - 6M, Jan '18 - 8M, Jul '17 - 8M, Jan '17 - 8M, Jul '16 - 5M, Jan '16 - 8M, Jan '15 - 6M, MQP '15 - 4M, MQP '14 - 5M)
49. Explain the working of a clocked SR flip-flop with a suitable circuit, symbol, truth table and input-output waveforms considering positive edge triggered SR flip-flop. (Jul '18 - 6M)
50. With a neat circuit diagram and truth table, explain the working of a JK flip-flop.
(MQP '18 - 6M)
51. What is a flip-flop? Explain the operation of Master Slave JK flip-flop.
(Jan '20 - 8M, Jul '19 - 6M, MQP '18 - 5M)
52. What are the differences between level-triggered and edge-triggered flip-flops?
53. What is a shift register? Explain the working of a 4-bit SISO shift register. (MQP '18 - 8M)
54. Explain the working of a 4-bit shift register.
55. What is a counter? What are the differences between synchronous and asynchronous counters?
56. What is a counter? With a neat timing and block diagram, explain three-bit (Mod-8) asynchronous (ripple) counter operation.
(Jan '19 - 8M, MQP '18 - 7M)
57. With a block diagram, explain the working of a 3-bit ripple(asynchronous) counter.
(Jan '20 - 6M, Jul '19 - 6M)
58. With a neat block diagram, explain the operation of four-bit (Mod-16) asynchronous (ripple) counter.
59. With a neat block diagram, explain the operation of Mod-8 synchronous counter.
60. With a neat block diagram, explain the operation of Mod-16 synchronous counter.
61. Convert:
i) $(2467.125)_{10} = (?)_2 = (?)_{16}$
ii) $(765.16)_8 = (?)_{10} = (?)_2$
iii) $(101111.101)_2 = (?)_8 = (?)_{10}$ (Sep '20 - 8M)
62. Perform the following operations:
(i) $(ABC.E5F)_{16} = (?)_{10}$ (ii) $(100.974)_{10} = (?)_2$ (iii) $(1100111.0101)_2 = (?)_8$
(Sep '20 - 6M)
63. Perform the following operations:
(i) $(110.1101)_2 = (?)_{10}$ (ii) $(47.8125)_{10} = (?)_2$
(iii) $(31C.DE)_{16} = (?)_{10}$ (iv) $(11010.101)_2 = (?)_{16}$ (Sep '20 - 6M)
64. Find
(i) $(1101011101101010)_{16} = (?)_2$ (ii) $(EB986)_{16} = (?)_2$ (iii) $(925.75)_{10} = (?)_8$

(Jan '20 - 6M)

65. Convert the following:

(i) $(283.728)_{10} = (?)_8$ (ii) $(AB.5E)_{16} = (?)_8$

(Jan '20 - 6M)

66. Convert the following:

(i) $(12.125)_{10} = (?)_2$ (ii) $(10AB)_{16} = (?)_2$
(iii) $(101010111100)_2 = (?)_{16}$ (iv) $(57.6)_8 = (?)_2$

(Jan '20 - 4M)

67. What are radix-2, radix-8, radix-10 and radix-16 number systems? Perform the following operations:

(i) $(1234.56)_8 = (?)_{10}$ (ii) $(BAD.DAD)_{16} = (?)_8$ (iii) $(988.86)_{10} = (?)_{16}$

(Jul '19 - 8M)68. Convert $(1101010)_2 = (?)_{10}$ and $(65)_{10} = (?)_2$.**(Jul '19 - 4M)**69. Convert $(ABCD)_{16} = (?)_8$ and $(16000)_8 = (?)_{16}$.**(Jul '19 - 4M)**

70. Find:

(i) $(1010111011110101)_2 = (?)_{16}$ (ii) $(FA876)_{16} = (?)_2$

(Jan '19 - 4M, MQP '15 - 4M)

71. Interpret the following:

i) $(48350)_{10} = (?)_{16} = (?)_8$

ii) $(FACE)_{16} = (?)_2 = (?)_8$

iii) $(847.951)_{10} = (?)_8$

(Jan '19 - 6M)

72. Convert:

i) $(1AD.E0)_{16} = (?)_{10} = (?)_8$

ii) $(1101101)_2 = (?)_{10}$

iii) $(69)_{10} = (?)_2$

(Jan '19 - 5M)

73. Convert the following:

i) $(725.25)_{10} = (?)_2 = (?)_{16}$

ii) $(111100111110001)_2 = (?)_{10} = (?)_{16}$

(MQP '18 - 8M)

74. Convert:

i) $(11001.011)_2 = (?)_{10}$

ii) $(64.73)_8 = (?)_{16}$

iii) $(186.75)_{10} = (?)_2$

iv) $(ABCD)_{16} = (?)_2$

(Jul '18 - 8M)

75. Convert the following binary numbers to octal number system:

(i) 1011.1111 (ii) 111100111110001

(Jul '18 - 4M)

76. Convert:

i) $(172.625)_{10} = (?)_{16} = (?)_2$

ii) $(BCDE)_{16} = (?)_2 = (?)_8$

iii) $(10111101.0110)_2 = (?)_{10} = (?)_{16}$

(Jan '18 - 6M)

77. Convert:

i) $(2AD.E3)_{16}$ to its octal and decimal equivalents.

ii) $(1456.72)_8$ to its decimal and hexadecimal equivalents.

(Jan '18 - 4M)

78. Convert the following:
 i) $(49.5)_{10} = (?)_{16}$
 ii) $(1062.403)_8 = (?)_{10}$
 iii) $(642.71)_8 = (?)_2$ **(Jul '17 - 6M)**
79. Convert:
 i) $(655.70)_8 = (?)_{10} = (?)_{16}$
 ii) $(238.20)_{10} = (?)_8 = (?)_2$ **(Jul '17 - 8M)**
80. Convert $(1101101)_2 = (?)_{10}$ and $(96)_{10} = (?)_2$. **(Jan '17 - 4M)**
81. Convert $(FA876)_{16} = (?)_8$ and $(237)_8 = (?)_{16}$. **(Jan '17 - 4M)**
82. Convert:
 i) $(1010101)_2 = (?)_{10} = (?)_8$
 ii) $(ABCD)_{16} = (?)_2 = (?)_8$ **(Jan '17 - 5M)**
83. Convert:
 i) $(526.44)_8 = (?)_2 = (?)_{10}$
 ii) $(48350)_{10} = (?)_{16} = (?)_8$ **(Jul '16 - 4M)**
84. Convert:
 i) $(342.56)_{10} = (?)_2 = (?)_8$
 ii) $(BCDE) = (?)_2 = (?)_8$ **(Jul '16 - 4M)**
85. i) Convert A6B.F5 to binary
 ii) Convert binary 110.111 into decimal equivalent **(Jul '16 - 6M)**
86. Convert the following:
 (i) $(172.625)_{10} = (?)_2$ (ii) $(ABCD.72)_{16} = (?)_8$ (iii) $(10111101.0101)_2 = (?)_{10}$ **(Jan '16 - 6M)**
87. Convert (i) $(35.45)_{10} = (?)_2$ (ii) $(475.25)_8 = (?)_{10}$ (iii) $(3FD)_{16} = (?)_2$ **(Jan '16 - 6M)**
88. Perform the following conversions:
 (i) $(1234.56)_8 = (?)_{10}$ (ii) $(10110101001.101011)_2 = (?)_{16}$ (iii) $(988.86)_{10} = (?)_2$
 (iv) $(532.65)_{10} = (?)_{16}$ (v) $(ABCD.EF)_H = (?)_8$ **(Jul '15 - 5M)**
89. Convert (i) $(294.6875)_{10} = (?)_8$ (ii) $(356.15)_8 = (?)_2 = (?)_{10}$. **(Jan '15 - 5M)**
90. Convert $(1101101)_2 = (?)_{10}$ and $(69)_{10} = (?)_2$. **(MQP '15 - 4M)**
91. Convert (i) $(1AD.E0)_{16} = (?)_{10} = (?)_8$ (ii) $(356.15)_8 = (?)_2 = (?)_{10}$ **(MQP '14 - 5M)**
92. Perform the following:
 i) Convert $(925.75)_{10}$ to base-2 and base-16.
 ii) Subtract $(11011.11)_2$ from $(10101.11)_2$ using 2's complement method. **(Jul '19 - 6M)**
93. Perform the following:
 i) Convert $(ABCD)_{16} = (?)_2 = (?)_8 = (?)_{10}$
 ii) Subtract $(1010)_2 - (111)_2$ using 2's complement method. **(MQP '18 - 5M)**
94. Perform the following:
 i) Convert $(111110101101)_2$ to $()_8$

- ii) Subtract $(22)_{10} - (17)_{10}$ using 1's and 2's complement method. **(MQP '18 - 5M)**
95. Perform the following:
- i) Convert $(57345)_{10} = (?)_{16}$
- ii) Subtract $(28)_{10} - (19)_{10}$ using 2's complement method. **(Jan '18 - 6M)**
96. Perform the following:
- i) Convert $(FA27D)_{16} = (?)_2 = (?)_8 = (?)_{10}$
- ii) Subtract $10.0101 - 101.1110$ using 1's complement method. **(Jan '18 - 6M)**
97. Perform the following:
- i) Convert $(725.25)_8 = (?)_{10} = (?)_2$
- ii) Subtract using 2's complement $(4 - 9)_{10}$
- iii) $(11010.101)_2 = (?)_8 = (?)_{16}$ **(Jan '18 - 6M)**
98. Subtract:
- i) $(11011.11)_2 - (10101.11)_2$ using 1's complement method
- ii) $(10101.11)_2 - (11011.11)_2$ using 2's complement method **(Sep '20 - 6M)**
99. Subtract:
- i) $(1011)_2 - (110)_2$ using 1's complement
- ii) $(1001)_2 - (1110)_2$ using 2's complement **(Jan '20 - 6M)**
100. Perform binary subtraction using 1's and 2's complement method for the following:
- (i) $15 - 13$ (ii) $28 - 19$ **(Jan '20 - 8M)**
101. Perform the following using 2's complement method:
- (i) $(15)_{10} - (28)_{10}$ (ii) $(1011.10)_2 - (1000.01)_2$ **(Jul '19 - 5M)**
102. Perform the following subtraction using 1's and 2's complement: $(10111001)_2 - (1011)_2$. **(Jul '19 - 6M)**
103. Subtract the following using 2's complement:
- i) $(11100)_2 - (10011)_2$ **(Jan '19 - 2M)**
104. Perform the subtraction using 2's complement method:
- i) $(11010)_2 - (10000)_2$
- ii) $(11)_{10} - (15)_{10}$ **(Jan '19 - 5M)**
105. Perform the subtraction:
- i) $(11010)_2$ and $(1101)_2$ using 1's complement method
- ii) $(11010)_2$ and $(01101)_2$ using 2's complement method **(Jan '19 - 7M)**
106. Subtract the following using 2's complement method:
- i) $(111001)_2 - (101011)_2$
- ii) $(1111)_2 - (1011)_2$ **(Jul '18 - 6M)**
107. Subtract $(1000.01)_2$ from $(1011.10)_2$ using 1's and 2's complement method. **(Jul '18 - 6M)**
108. Subtract $(1111.101)_2$ from $(1001.101)_2$ using 1's and 2's complement method. **(Jan '18 - 6M, MQP '14)**
109. Perform the following:

- i) $(11010)_2 - (10111)_2$ using 1's complement method
 ii) $(111001)_2 - (101011)_2$ using 2's complement method **(Jul '17 - 8M)**
110. Subtract $(111001)_2$ from $(101011)_2$ using 2's complement method. **(Jan '17 - 5M, Jul '16)**
111. Subtract $(19)_{10}$ from $(15)_{10}$ using 1's and 2's complement methods. **(Jan '17 - 6M)**
112. Subtract $(101011)_2$ from $(111001)_2$ using 2's complement method. **(Jul '16 - 4M)**
113. Perform the subtraction:
 i) $(11010)_2 - (10000)_2$ using 1's complement
 ii) $(1000100)_2 - (1010100)_2$ using 2's complement **(Jul '16 - 4M)**
114. Perform the subtraction with the following binary numbers using 1's and 2's complement method: (i) $11010 - 1101$ (ii) $10010 - 10011$ **(Jul '16 - 6M)**
115. Perform the following operations using 1's and 2's complement technique:
 (i) $(56)_{10} - (79)_{10}$ (ii) $(23)_{10} - (18)_{10}$ **(Jan '16 - 6M)**
116. Subtract $(111001)_2$ from $(101011)_2$ using 2's complement method. **(Jan '16 - 4M)**
117. i) Subtract $(1000.01)_2$ from $(1011.10)_2$ using 1's and 2's complement method.
 ii) Add $(7AB.67)_{16}$ with $(15C.71)_{16}$ **(Jul '15 - 5M)**
118. Subtract $(111)_2$ from $(1010)_2$ using 1's and 2's complement method. **(Jan '15 - 5M)**
119. Subtract $(11101.111)_2$ from $(11111.101)_2$ using 2's complement method. **(MQP '14 - 5M)**
120. Simplify the following Boolean expressions:
 i) $Y = A\bar{B} + AB$
 ii) $Y = AB + AC + BD + CD$
 iii) $Y = (B + CA)(C + \bar{A}B)$
 iv) $Y = \bar{A}\bar{B}\bar{C}\bar{D} + \bar{A}\bar{B}\bar{C}D + A\bar{B}\bar{C}\bar{D} + A\bar{B}C\bar{D}$ **(MQP '18 - 8M)**
121. Simplify the following Boolean expressions:
 i) $AB + \bar{A}\bar{C} + A\bar{B}C (AB + C)$
 ii) $\overline{\bar{A}B + ABC} + A(B + \bar{A}B)$ **(Jul '18 - 6M, MQP '14 - 5M)**
122. Simplify the Boolean function $F = \bar{A}BC + A\bar{B}C + ABC$. **(Jul '17 - 4M)**
123. Prove the following Boolean identity using truth table:
 (i) $A + AB = A$ (ii) $A + \bar{A}B = A + B$ **(Jul '16 - 4M)**
124. Show that:
 i) $\bar{A}BC + B + B\bar{D} + AB\bar{D} + \bar{A}C = B + C$
 ii) $\overline{\bar{A}B + \bar{A}} + AB = 0$
 iii) $AB + A(B + C) + B(B + C) = B + AC$ **(Jan '16 - 6M)**
125. Simplify the Boolean expression: $\overline{xy + xyz + x(y + x\bar{y})}$. **(Jan '18 - 4M)**
126. Factorise the following Boolean equations: $Y_1 = \bar{A}B + AB$, $Y_2 = (B + CA)(C + \bar{A}B)$. **(MQP '15 - 6M)**
127. Prove and implement by using basic gates:
 i) $A + \bar{A}B = A + B$

- ii) $(A + B)(A + C) = A + BC$ **(Sep '20 - 4M)**
128. Simplify the following Boolean expressions and realize using basic gates:
- i) $Y = A + \bar{A}B + A\bar{B}C + A\bar{C}$
- ii) $Y = (A + \bar{B} + \bar{C})(A + \bar{B} + C)$ **(Jan '20 - 6M)**
129. Simplify and realize the following Boolean expressions using basic gates:
- i) $Y = \bar{A}\bar{B}\bar{C} + \bar{A}\bar{B}C + \bar{A}B\bar{C} + A\bar{B}\bar{C}$
- ii) $Y = ABC + \bar{A}\bar{B}C + A\bar{B}\bar{C} + \bar{A}BC$
- iii) $Y = (\bar{A} + \bar{B})(\bar{A} + \bar{C})(\bar{B} + C)$ **(Jul '19 - 8M, Jan '15 - 6M)**
130. Simplify $S = A \oplus B \oplus C$ and realize using basic gates. **(Jul '19 - 5M)**
131. Simplify the following expression and realize using basic gates: $Y = A(\bar{A}\bar{B}C + \bar{A}BC)$.
(Jan '19 - 4M, Jul '16 - 4M)
132. Simplify the following expressions and draw the logic circuits using basic gates:
- i) $AB + \bar{A}C + \bar{A}\bar{B}C (AB + C)$
- ii) $(A + \bar{B})(CD + E)$ **(MQP '18 - 6M)**
133. Simplify the following expression and realize using basic gates: $Y = ABC + AB\bar{C} + \bar{A}BC$.
(Jan '18 - 5M)
134. Simplify the expression and realize using basic gates: $\bar{A}\bar{B}\bar{C} + \bar{A}B\bar{C} + A\bar{B}\bar{C} + A\bar{B}C$.
(Jan '18 - 5M)
135. Simplify and realize the expression using basic gates: $Y = \bar{A}\bar{B} + \bar{A}C + A\bar{B}\bar{C} + \overline{AB + C}$.
(Jan '18 - 6M)
136. Simplify and realize using basic gates: $\bar{X}\bar{Y}\bar{Z} + \bar{X}\bar{Y}Z + \bar{X}Y\bar{Z} + X\bar{Y}$. **(Jan '17 - 5M)**
137. Simplify $Y = AB + ABC + \bar{A}B + \bar{A}\bar{B}C$ and construct logic circuit. **(Jul '16 - 4M)**
138. Simplify and realize the following using only NAND gates only:
 $Y = AC + ABC + \bar{A}BC + AB + D$ **(MQP '18 - 4M)**
139. Simplify and realize the following using only NAND gates: $Y = A\bar{B}\bar{C} + \bar{A}\bar{B}\bar{C} + \bar{A}\bar{B} + \bar{A}\bar{C}$.
(Jul '18 - 5M, Jan '17 - 5M, MQP '18 - 4M)
140. Realize $Y = AB + CD + E$ using NAND gates. **(MQP '18 - 4M, Jan '18 - 6M)**
141. Simplify the given Boolean equation $Y = (A + \bar{B})(CD + E)$ and realize using NAND gates only. **(Jul '17 - 4M)**
142. Realize the following using only NAND gates: $Y = (A + \bar{B} + C) \cdot (\bar{A} + B + C)$.
(Jan '20 - 4M, Jan '17 - 5M)
143. Simplify and realize the Boolean expression using two input NAND gates only:
 $(A + \bar{B} + C)(\bar{A} + B + C)$. **(Jan '18 - 5M)**
144. Simplify $Y = A + \bar{A}B + \bar{A}BC$ and implement using logic gates and NOR gates. **(Jan '18 - 6M)**
145. Simplify $Y = \bar{A}BC + \bar{A}\bar{B}C + ABC$ and then realize using
(i) basic gates only (ii) NOR gates only **(Jan '20 - 8M)**
146. Construct a circuit for the expression $X = AB + CD$ using

(i) only NAND gates (ii) only NOR gates **(Sep '20 - 4M)**

147. Simplify and realize the following expressions using only NAND and NOR:

(i) $Y = (A + \bar{B})(B + C)(\bar{C} + \bar{B})$ (ii) $Y = AB + AC + BD + CD$ **(Jan '16 - 10M)**

148. Design a logic circuit using basic gates with three inputs A, B, C and output Y that goes low only when A is high and B and C are different. **(MQP '14 - 5M)**

Communication Systems

1. Define communication. **(Jan '18)**
2. With a neat block diagram, explain the elements of a communication system.
(Jan '20 - 6M, Jan '19 - 6M, Jul '18 - 4M, Jan '18 - 6M, Jul '17 - 6M, Jan '17 - 5M, Jul '16 - 6M, MQP '15 - 5M)
3. Explain the basic block diagram of communication system. **(Sep '20 - 6M)**
4. With a block diagram, explain the working of basic communication system.
(Jul '19 - 5M, MQP '18 - 6M)
5. Draw the block diagram of communication system and explain the functions of each block used in it. **(Jul '19 - 5M)**
6. With neat diagrams, explain the principle of operation of mobile phone.
7. With a neat block diagram, explain GSM system. **(MQP '18 - 6M)**
8. With a neat block diagram, explain the operating principle of the GSM system.
(MQP '18 - 6M)
9. With a neat block diagram, explain cellular telephone unit.